

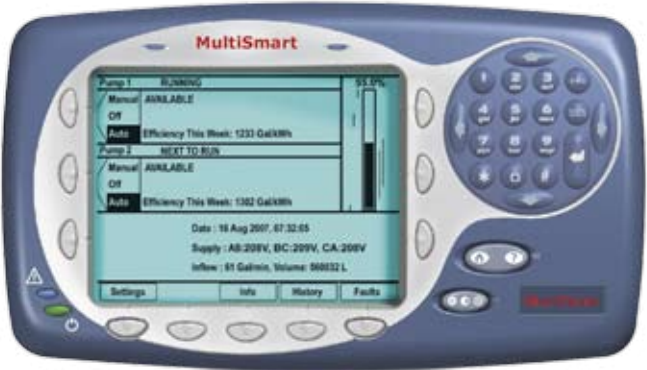

MultiSmart Pump Station Manager.

The new face of technology.

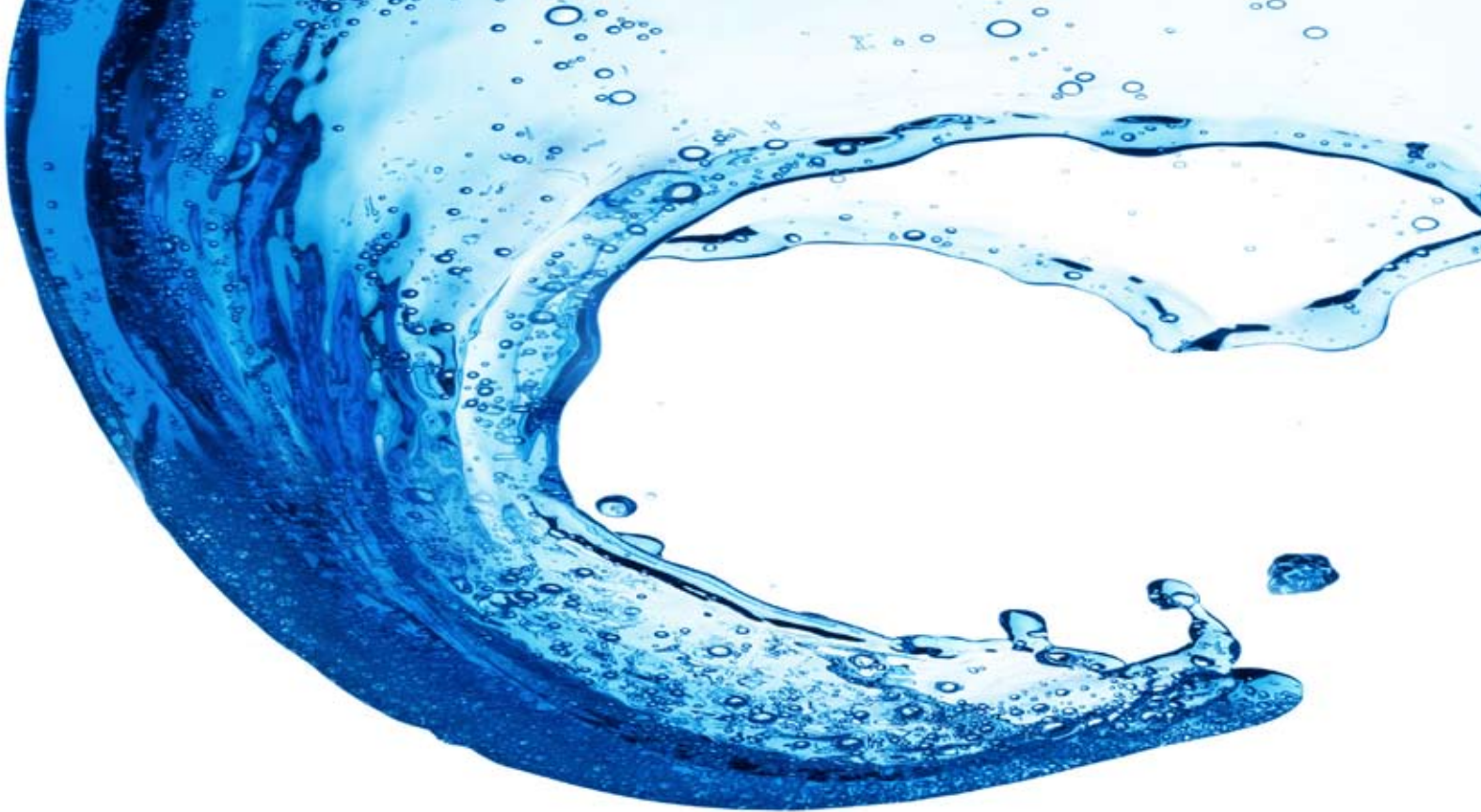



What is a pump station manager?

It's the next generation of technology for water & wastewater pump stations – combining the best of PLCs, RTUs and pump controllers into a comprehensive and intuitive package.

The pump station manager also integrates up to 15 control panel components, reducing control panel cost and enabling energy cost/CO₂ reduction.

Why choose MultiSmart?

MultiSmart was designed to make Utilities better managers of their assets.

Benefits include:

- Lower cost of control panel (over \$10,000 is often achievable).
- Reduces operational costs by up to 70%.
- Reduces energy costs & CO₂ footprint by up to 15%.
- Wealth of asset management data.

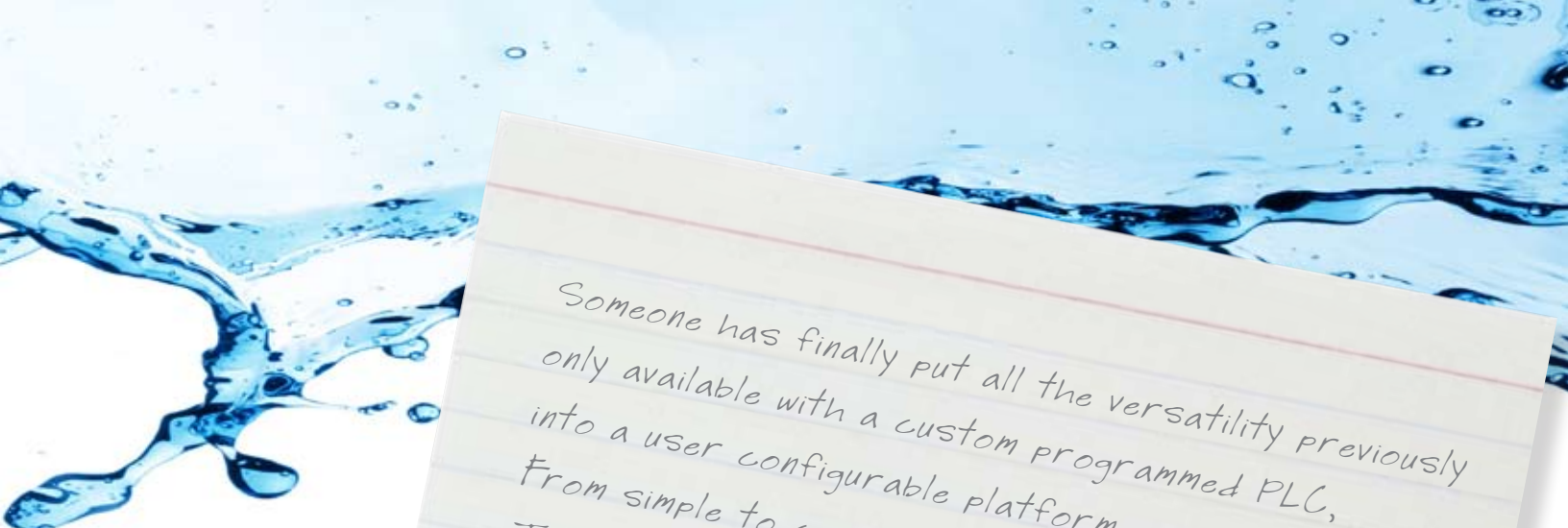



Someone has finally put all the versatility previously only available with a custom programmed PLC, into a user configurable platform. From simple to complex, this unit handles it all. The wealth of pump station operational information available to the end user is virtually limitless.

J.C. Van Harn, President, GrandTech Inc., Byron Centre, Michigan.

MultiSmart at a glance.

- “Setup wizard” for commissioning of a new station
- Save/Copy configuration using compact flash card
- Advanced pump control functionality for up to 6 pumps
- Flow without a flow meter
- Data logger for 50,000 events (10,000,000 direct to CF card)
- History page with detailed fault & event data
- 3-phase supply voltage monitoring and protection
- Flexible RTU with Modbus & DNP3 protocol for SCADA & local connectivity
- Energy, power & pump efficiency monitoring
- Expandable I/O

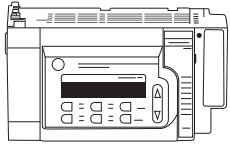
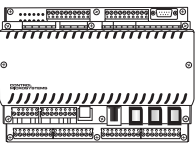
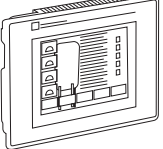
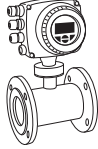
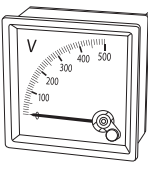
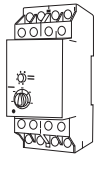
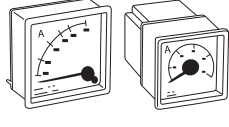
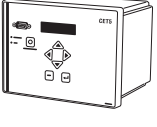
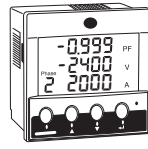
Why invest in PLCs, RTUs, pump controllers and \$1000s of programming...

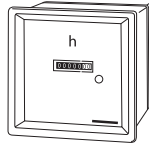
<p>PLC</p> 	<p>RTU</p> 	<p>HMI</p> 	<p>FLOWMETER</p> 
<p>VOLTMETER</p> 	<p>PHASE FAIL RELAY</p> 	<p>CURRENT METER</p> 	<p>MOTOR PROTECTION</p> 
<p>ENERGY & POWER METER</p> 	<p>INSULATION RESISTANCE TESTER</p> 	<p>HOURS RUN METER</p> 	<p>\$10,000s of design, programming and integration.</p>

when MultiSmart does it all.





Easy to use.

If you're in operations you know how important it is to get the right information when you're on site. Instead of a few flashing lights – which don't tell you anything – MultiSmart gives you comprehensive information on past and current problems.

Correct use of the MultiSmart encourages better decision making, better use of staff and leads to reduced operational costs.

Fault Name	Status
Thermal Fault on Pump 1	Reset Required
Seal Fault on Pump 2	Present

Fault Triggered @ 06/06/2005 00:39:59
 Fault Cleared @ 06/06/2005 00:40:48
 Reset required to deactivate fault. Press 'Reset Fault' to deactivate.
 Devices Affected : Pump 1

Reset Fault

Back History

Fault screen

Flow Statistics		Select
Rate	Value	
Station Inflow Rate	45 gals/min	
Pump 1 Outflow Rate	912 gals/min	
Pump 2 Outflow Rate	930 gals/min	
Volume Pumped Today	96328 gals	
Volume Pumped Yesterday	131399 gals	
Volume Pumped This Week	405743 gals	
Volume Pumped Last Week	846697 gals	
Total Volume Pumped	63052320 gals	
Number of Overflows	1	
Last Overflow Time	15:13:05 34 Mar 2006	
Total Overflow Volume	5407 gals	

Back Pg Up Pg Dn Set Reset

Flow screen

Power and Efficiency			Page
	Pump 1	Pump 2	
Power (kW)	11.3	0	
Power Factor (%)	96%	0	
Efficiency (L/kWh):			
Today	8330	4108	
Yesterday	6540	6045	
This Week	6635	6197	
Last Week	6600	6133	
This Month	6590	6064	
Last Month	6821	6085	
Benchmark	7021	6079	
Energy (kWh):			

Back Set Reset

Power and pump efficiency screen

Station Settings - P1 of 3	
Set Points	I/O, Faults & Level
Level and alarm setpoints, enable/disable alarms, delays & level simulation.	Link faults to inputs, configure faults, primary and backup level source.
Setup Wizard	Station Optimization
Commission a station - Fill/Empty mode, number of pumps, wells, level device.	Color reduction, well clean-out, backup pump detection, max run time, max station starts, max pumps to run, profiles, etc.
Alternation & Grouping	Commission/Decom
Alternation, fixed sequence and multiple groups of pumps.	Take pumps in and out of service.

Main Advanced More

Easy setup – Settings Menu 1

The MultiSmart is easy to use, expands to accomplish practically any sequence of operation that is required and offers a degree of reliability and functionality that cannot be cost effectively reproduced with a traditional programmable logic controller.

Gregory Shofer, Project Manager, Stantec, Ann Arbor, Michigan.

Easy to configure.

As soon as you start using the MultiSmart user interface you'll appreciate how easy it is to commission a new station – or to change the way an existing station operates to make it more efficient and cost effective.

The MultiSmart has hundreds of functions designed specifically to meet the needs of water & wastewater pump stations. From something as simple as changing setpoints or how a fault condition affects a pump, through to complex alternation schemes for large pump stations, you'll see how the MultiSmart puts the operational staff back in charge.

The beauty of the MultiSmart is that the defaults have been carefully thought out so that when a station is commissioned almost everything is working how you would like it. But nothing is fixed – so any parameter can be changed. Making it quick to set up but always adaptable.

And for challenging applications where a new feature is required – there's an IEC61131-3 compliant PLC extension to MultiSmart – so that any system integrator can extend the functionality further, giving you the flexibility of a PLC without the headaches.

MultiSmart has hundreds of features. (Here are just a few).

Max run time for a pump (switch to next pump and raise an alarm).

Odour reduction via max off time (ensures wells do not become septic).

Run the **most efficient** pump (instead of alternation).

Clean the well out every Monday morning (to just above the snore point of the pump).

Multiple setpoint profiles – allows remote switching or on date/time for spill management, energy reduction.

Generator profile – change setpoints and limit max pumps to run when generator operating.

'Locked level' – raise an alarm when the level has not changed enough in a given time period (suspect level device).

Each **fault configurable** as display only, hold out pump until fault clears, hold out pump until operator intervention, retry pump a set number of times after fault condition clears then finally lock out.

Optional **VFD module** to control one or more pumps, with easy setup.

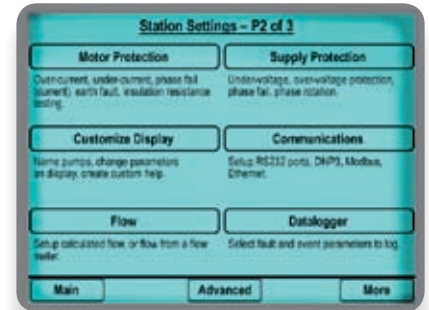

Easy setup – Settings Menu 2

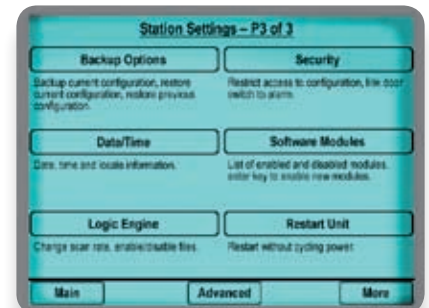

Easy setup – Settings Menu 3

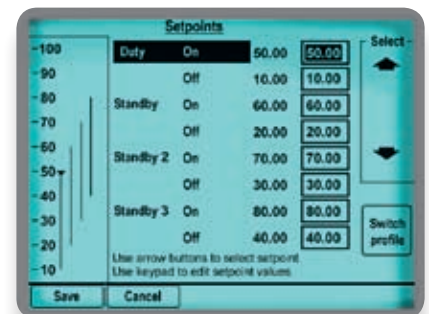

Changing Setpoints – intuitive

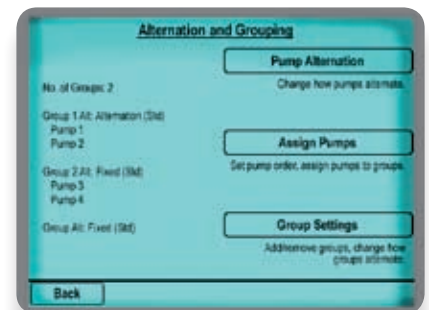

Complex pumping arrangements – made easy



Saving Costs – Capital and Operational.

Components that can usually be removed from a MultiSmart panel.

PLC/RTU or Pump Controller & RTU

HMI (display)

Flow meter

Voltmeter & selector switch

Phase fail relay

Current meter x3

Motor protection relay x2

Insulation resistance automatic tester

Energy & power meter x2

miniCAS (or other pump) relay x2

Saving costs in a Control Panel.

The MultiSmart pump station manager includes a number of the components in a control panel, bringing some major benefits:

- Lower cost of the control panel – typically \$5,500 lower material and labor cost, but in many cases much higher.
- Smaller panel – less impact on the community.
- Lower deployment and commissioning cost – one UK water utility calculated up to \$7,000 saving in staff on site due to smaller panel.
- Predictive maintenance indicators.
- Fault-finding data to get to the root cause of problems.
- Remote control – reset of faults and pump auto/manual/off from the SCADA.
- Better asset management data to a SCADA system.

Why Predictive Maintenance guarantees the best results.

Predictive Maintenance, also known as Condition Based Monitoring, is the ideal maintenance strategy because it identifies when assets need to be replaced – allowing the utility to plan cost-effective maintenance. However, most utilities are using Run to Fail or Preventive Maintenance Indicators as their maintenance strategy. This is because Predictive Maintenance has historically been considered too expensive to adopt. Critically, both Run to Fail and Preventive Maintenance have inherent flaws.

What's wrong with Run to Fail?

Run to Fail often seems like a low cost solution, but it has two major problems:

- a) When a pump fails, what is the guarantee that the other pump is operational?
Adopting a proactive approach to maintenance is far likelier to be viewed favorably by an EPA than adopting a 'hope for the best' approach.
- b) Without any visibility of the state of the assets prior to failure there is no guarantee that you are not running them into the ground. For example, one large utility found that a high proportion of its pumps failed after 7-8 years. The cause, identified by MultiTrode equipment, was that the 3-phase supply was too low, causing high running currents and reducing the life of the insulation on the motor windings. But at 5 years, the utility might have been feeling very confident that its low cost approach was working well.

Over the past six months, we have tested and installed six MultiSmart pump station managers and have been very pleased with the performance and ease of installation. The MultiSmart is reliable, easy to use and offers additional monitoring capabilities compared to other pump controllers we have used. Our field staff have all seen the benefits over float controls and in the future we will be looking to convert all our stations.

Frank McShane, Manager of Operations, East Gippsland Water Authority.

What's wrong with Preventive Maintenance?

Preventive Maintenance, or regular planned maintenance based on time in the field or equipment usage, is not a bad strategy. It's just not the best strategy. Preventive Maintenance clearly identifies that assets need maintenance but the frequency can only ever be a guess and often the maintenance is too frequent on some assets and not frequent enough on others.

How does Predictive Maintenance work?

To ensure that the hydraulic and electrical state of the pump and motor can be clearly monitored, the MultiSmart pump station manager measures the following:

Parameter	Benefit
Flow rates per pump, total volume per pump	Identifies impellor wear problems.
Energy used per pump	Identifies energy cost for each pump.
Pump efficiency in gals/KWHr or litres/KWHr	Allows 'Run most efficient' algorithm to automatically save energy. Provides a measure of the cost of inefficiency to allow an ROI on service or replacement.
Insulation resistance per pump	Breakdown of motor windings causes 50-80% of motor failures. Pulling a pump and revarnishing is much lower cost than rewinding and can be done at a convenient time.
Supply voltage (all 3-phases)	Under-voltage leads to the windings running too hot, reducing the life of the motor significantly - and frequent trips by operations staff to reset "Pump Trip". Accurate monitoring allows a utility to rectify the underlying problem.
Current monitoring (all 3-phases)	Small imbalances in supply lead to larger current imbalances, causing uneven wear in bearings and windings running too hot.
Detailed fault analysis for each pump	Provides clear indication of which aspects of the electrical or hydraulic system need attention.

MultiSmart delivers a wealth of Asset Management Data.

SCADA systems for pump stations frequently only have a few points of data per site – pump running, pump fault, level, level alarm, mains fail and flow (if a flow meter is available on site). This doesn't provide a platform for asset management. Asset managers, capital works managers and utility directors need real data to plan for the future.

MultiSmart provides 400-500 tags (data points) per site.

This wealth of data includes Predictive Maintenance information, volumes through the station, energy usage, peak power requirements and detailed fault information – allowing the utility to find out where their real costs lie.

MultiSmart also simplifies remote control – turning pumps on and off, resetting faults and changing setpoints.



Which SCADA does MultiSmart connect to?

MultiSmart has a sophisticated RTU with Modbus & DNP3. The MultiSmart DNP3 implementation has been independently audited and proven to comply with the standard. MultiSmart has capacity for multiple masters and slaves to be configured allowing connection to any other modern SCADA platforms.

MultiSmart also supports connection over serial radio, ethernet radio, cellular data, cellular voice and phone lines.

Pre-designed SCADA

Any modern SCADA can connect to MultiSmart, but some vendors have already done the hard work, with screens and reports developed for the rich MultiSmart data as well as an "Add MultiSmart site" function.

Outpost2 from MultiTrode, visit multitrode.com/outpost2-scada-software to learn more.

VTS from Trihedral, visit trihedral.com

And PumpView is a secure on-line monitoring and control system, hosted by MultiTrode.

Visit multitrode.com/pumpview



Citect

RSView
from Rockwell
Automation

ClearSCADA



iFix and Cimplicity
from GE FANUC

Genesis 32
from Iconics

and any other modern SCADA platform.

MultiSmart reduces your energy costs and CO₂ footprint.

With energy costs rising and water & wastewater utilities concerned about their social responsibility, reducing energy use is a high priority.

MultiSmart measures the energy used for each pump, calculates the flow (or uses the data from a flowmeter if available) and derives the efficiency (gals/kWhr or litres/KWhr) of each pump in your network.

MultiSmart also includes an algorithm for automatically running the most efficient pump. The data on the energy cost per pump allows you to do an ROI calculation on servicing or replacing an inefficient pump.

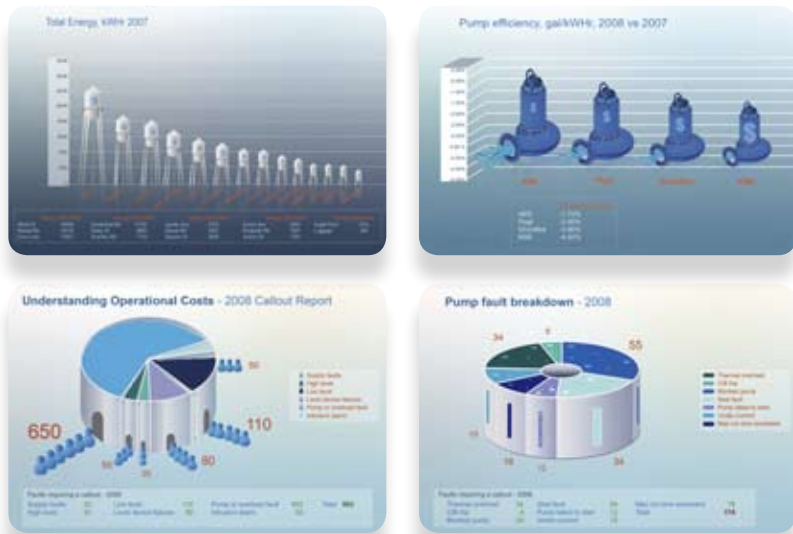

Examples of reports and graphics created using data from MultiSmart

The City of Tavares has been using the Multismart products for just under a year. I can't imagine how we did it before; we can now monitor and control every station with speed and with the accuracy of information we require. We have also found the flow calculations invaluable for I&I studies during rain events. Our experience with the product and tech support to date has been excellent. We highly recommend Multitrode and its products. The City of Tavares have standardized on MultiTrode products and stand by them.

Brad Hayes, Utilities Director & Jerry Blair, Supervisor, City of Tavares, FL.

Pays for itself.

One UK water utility using MultiSmart found that one of their pumps in a 3-pump station was very inefficient and as a result the replacement cost of the impellor would be paid for within 95 days.

Improves pump efficiency.

Many water & wastewater utilities are unaware of how much pump efficiency can degrade, even in clean water.

A drop of 10% in efficiency in the first 10 years of service in a clean water pump is not uncommon. And a drop of over 20% in wastewater pumps is often found. MultiSmart helps address these problems.



MultiSmart gives you total control.

There are many remote sites within a water & wastewater network that don't contain any pumps – e.g. valve monitoring and control, flow meters, pressure and reservoirs. To help you get the most out of every aspect of your Utility, MultiSmart is also available in an RTU-only version and as a product called the Reservoir Monitor.

RTU-only.

The MultiSmart can be purchased and used just as an RTU. The physical appearance is exactly the same – a unit which includes a host processor & communications board, a DSP board for processing IO at high speed and IO cards, and a display. Unlike a standard RTU, which has contact closure digital inputs (DINs), the MultiSmart RTU can be configured as either contact closures or high speed counters.

To help cut costs and complexity it can be configured to measure:

- Conductive level sensors.
- Seal sensors.
- PTC thermistors.
- Flygt FLS and CLS sensors.

The MultiSmart RTU I/O also measures 3-phase voltage (direct phase up to 600v) and 3-phase currents (direct from 5A CTs).

Because of the high speed DSP processor, the voltage and current measurements can be used to accurately calculate:

- Power, KW.
- Power factor.
- Apparent power, KVA.
- Energy, KWHr.
- Apparent energy, KVAH.

The MultiSmart RTU also includes standard 4-20mA AINs, 4-20mA AOUTs and DOUTs along with the configurable DINs.

Reservoir Monitor.

The MultiSmart Reservoir Monitor was designed for reservoirs filled from remote pump stations. It includes functionality for communicating directly to the remote pump station as well as the SCADA system. The user interface works in exactly the same way, with the same menu structure, as the MultiSmart Pump Station Manager. So no extra training is required.



Specifications.

Processor, Comms, I/O, Display, Power Supply, Environmental.

Processor Unit

TYPE	Intel PXA255
SPEED	200MHz
FLASH MEMORY	32MByte
RAM	64MByte
REAL TIME CLOCK	Yes
SERIAL PORTS	RS232 x 3, 115kBit/s
ETHERNET PORT	10Mbit/s
COMPACT FLASH	For firmware upgrades, configuration save/load, datalogging

RTU/communications

PROTOCOLS	DNP3 level 2, Modbus (RTU, ASCII, TCP)
MEDIA	TCP, UDP, RS232, 3G/GPRS/CDMA (1XRTT), PSTN/GSM/CDMA,
DATALOGGING	Change of state for digital, deadbanding for analog. Date/time and quality stamped

PLC specification

PROGRAMMING CAPABILITY	IEC61131-3 (configured via IsaGRAF workbench)
REFERENCE TO EXISTING FUNCTIONAL BLOCKS	Via tag database

Configuration & Firmware upgrade

LOCAL	Compact Flash card or Ethernet from PC
REMOTE	Via DNP3 file transfer, or via FTP

I/O modules

MULTISMART CARD: IO-3PC	General I/O and Pump Control
DIN X 20	DINx 20 configurable as contact closure, counter, MultiTrode probe input, seal, thermistor or FLS. Of these inputs: <ul style="list-style-type: none">• 3 of the DINs have additional CLS capability• 2 of the DINs have additional high speed digital input capability (1kHz)• 1 of the DINs has additional failsafe probe capability
DOUT x 7	DOUTx 4 isolated voltage free contacts DOUTx 3 common voltage free contacts All rated 240Vrms, 5A
AIN x 2	2x 4-20mA inputs, 10bits, 0.2% resolution
AOUT x 1	1x 4-20mA outputs, 10bits, 0.2% resolution
VIN x 3	3-phase mains voltage inputs, 0.5% resolution. Up to 630V phase to phase
MULTISMART CARD: IO-3MP	Energy/Power Monitoring & Motor Protection board
IIN x 9	3 sets x 3-phase current inputs, derived from CTs, 0.5% resolution
IRT 1000v x 3	1000v dc to measure 0-20Mohm impedance on motor windings
DOUT x 5	5x isolated voltage free contacts, rated 240Vrms, 5A
AOUT X 3	3x 4-20mA output, 10bits, 0.2% resolution
ETHERNET IO MODULES:	General Analog and Digital I/O (connected via Modbus TCP to MultiSmart)
MSM-AD-8A / Adam 6017	8x AIN, 16-bit, differential; 2x DO open collector to 30V (not UL listed)
MSM-AD-18D / Adam 6050	12x DI, dry contact, 6x DO open collector to 30V (not UL listed)
ACROMAG 961EN-4006	6x AIN, 16-bit, differential, UL listed
ACROMAG 983EN-4012	12x DI or DO (any mix); DO open-drain to 35V DC max; DI active-low, buffered inputs, with a common connection, UL listed

Note: Any Modbus or DNP3 I/O module can be connected to MultiSmart – the above parts have been integrated into the user interface.

Specifications.

Continued

User interface

320x240 backlit LCD screen with soft-keys

Power supply & environmental

DC SUPPLY	11v-28v (DC supply voltage is monitored to 5% accuracy)
POWER	15W max. 11W max. (without IO-3MP board)
AMBIENT TEMPERATURE	-10°C to +60°C
STORAGE TEMPERATURE	-40°C to +80°C
HUMIDITY	5% to 95% non-condensing
Mains supply & battery backup	Option

Physical Product

CONTROLLER DIMENSIONS H 173 x W 217 x D 159 (mm)
H 6³/₄ x W 8¹/₂ x D 6¹/₄ (in)
IP Rating IP20

FACEPLATE DIMENSIONS H 144 x W 250 x D 42 (mm)
H 5⁵/₈ x W 9⁷/₈ x D 1⁵/₈ (in)
IP/Nema IP55 / Nema 12

*Please note: I/O and software modules supplied depend on the configuration purchased.
All specifications subject to change without notice.*

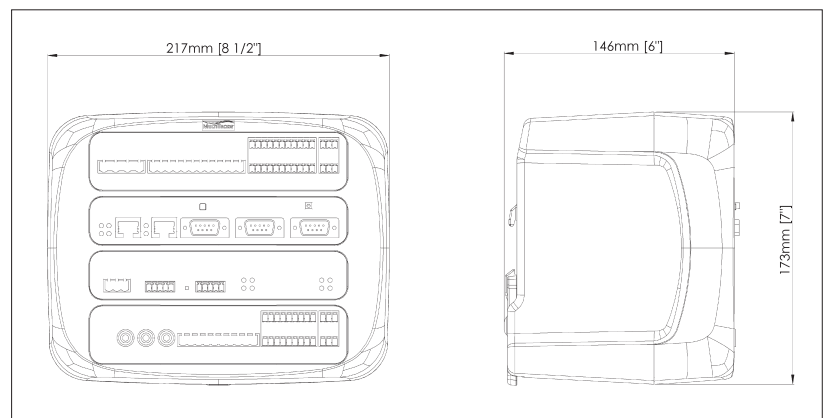
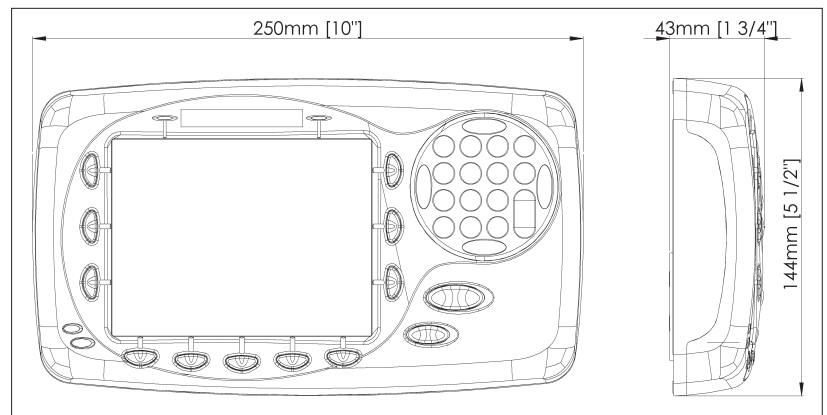

Functionality.

Subset provided below. For complete functionality, review the product manual or specification document, available at multitrode.com

Supply Protection.

Under-voltage fault, Over-voltage fault, Phase imbalance fault, Phase rotation fault.

Motor Protection.

Over-current, Under-current, Ground/earth fault, Phase imbalance (current), I²T.

Flow.

Calculated flow for emptying wells (e.g. wastewater) of known volume: Inflow, Individual Pump flow rates & volumes, Station Volumes.

Flow from a flow meter: Metered Flow & Volume – if only one value is available the other can be derived, inflow also available via volume of well. Flow alarms.

Energy, Power and Pump Efficiency.

Power kW, power factor, Apparent power KVA (derived from 3-phase voltage and 3-phase current).

Energy KWHr, Apparent energy KVAH.

Pump efficiency – litres/KWHr, litres/KVAH or gal/KWHr, gal/KVAH.

Datalogger.

Configured by setup wizard, but any event/fault can be added/deleted. Analog & accumulators logged on deadband.

50,000 events logged to internal memory – can be copied to Compact Flash.

10,000,000 events can be logged to external 2GB C.F. card.

Pump Control.

Level from 4-20mA device, conductive probe, ball floats, remote level, logic-derived value.

1-6 pumps, 7-9 pumps available dependant on number of s/w modules enabled in the unit.

1 or 2 wells, hydraulically connected or independent.

Alternation – fixed, lead/lag, N-1, by pump efficiency, by hours run, by starts.

Alternation Groups – pumps can be placed in groups and alternated by above scheme, with groups set to fixed or alternation.

Setpoints – adjustable in %, m, ft, or user-defined values.

Multiple Setpoint profiles – switchable via user-interface, DIN, logic, SCADA or internal date/time clocks. Setpoint profiles include parameters: max pumps to run, max run time, max off time.

Alarm Setpoints – 4 alarms: high, high-high, low, low-low; available to be enabled/disabled and adjusted if enabled.

Level Simulation – via user interface for station testing.

Max pumps to run (e.g. for duty/standby-duty/assist).

Max run time fault (switch to next pump to run).

Odour reduction via Max off time (stops wells becoming septic).

Well washer control.

Blocked pump detection.

Pulse start (pump or group).

Pulse stop (pump or group).

Remote auto/off/manual.

Remote fault reset.

Fault Module.

All faults configurable as display only, auto-reset (allow pump to start after fault condition clears), manual reset (wait for operator intervention via user interface or SCADA), auto-reset configurable number of times, then go to manual reset.

Pump fault inputs from variety of sources: Thermal PTC thermistor, seal, FLS, CLS, voltage-free digital input.

General faults also available to configure.



MultiTrode Inc - USA

Unit 3, 990 South Rogers Circle

Boca Raton Florida 33487

Tel: +1 561 994 8090 Fax: +1 561 994 6282

USSales@multitrode.com

MultiTrode UK

Ivybridge, Devon

Tel: +44 1752 547355 Fax: +44 1752 894615

UKSales@multitrode.com

MultiTrode Pty Ltd - Australia

Brisbane Technology Park 18 Brandl Street

PO Box 4633 Eight Mile Plains Qld 4113

Tel: +61 7 3340 7000 Fax: +61 7 3340 7077

AUSales@multitrode.com

MULTITRODE® and MULTISMART® are registered trademarks of MultiTrode Pty Ltd in Australia, USA, and Europe. PUMPVIEW® is a registered trademark of MultiTrode Pty Ltd in the USA and Australia. Designs registered for the MultiSmart Pump Controller Remote and Base Modules in Australia, USA, Europe and China. Patents pending in Australia, USA, and Europe. ©2009 MultiTrode Pty Ltd. This publication is protected by copyright. No part of this publication may be reproduced by any process, electronic or otherwise, without the express written permission of MultiTrode Pty Ltd.

multitrode

WATER • WASTEWATER • PUMP STATION • TECHNOLOGY